

# Motor Brush Replacement

## Tools Required:

- Flat-Blade Screwdriver

## Procedure:

- 1) Turn off power to the treadmill and unplug power cord from wall outlet.
- 2) Remove Brush Covers (Figures 1 & 2).

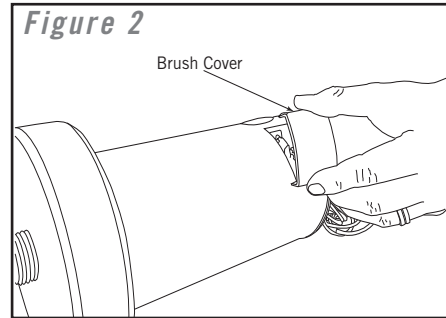
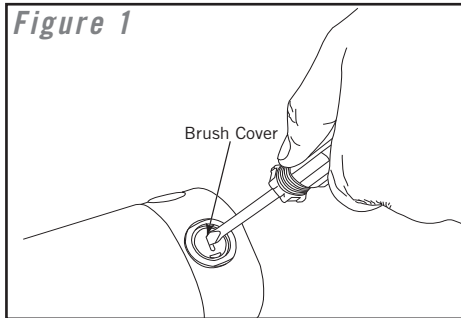

- 3) For models T61-T62, CST3.5, DT650/850, WT950 and 1.2T-2.2T only: Remove clip and spring holding motor brush, then remove motor brush (Figures 3 & 4).

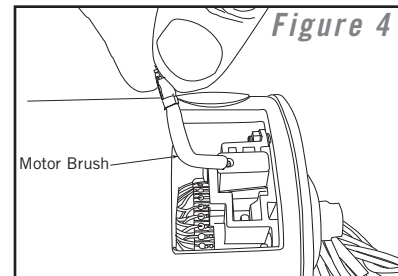
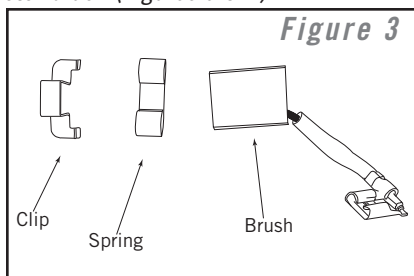

- 4) For models T63-T64, CST4.5, and 3.2T-5.2T only: Remove brushes (Figure 5).
- 5) Check the surface of the motor brush/brushes (Figure 6).

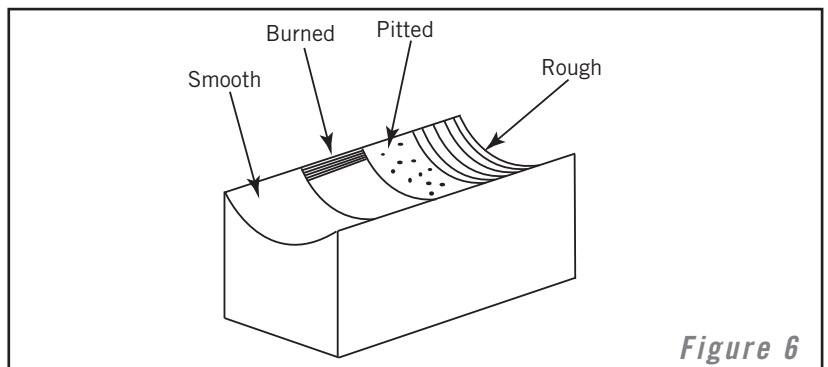
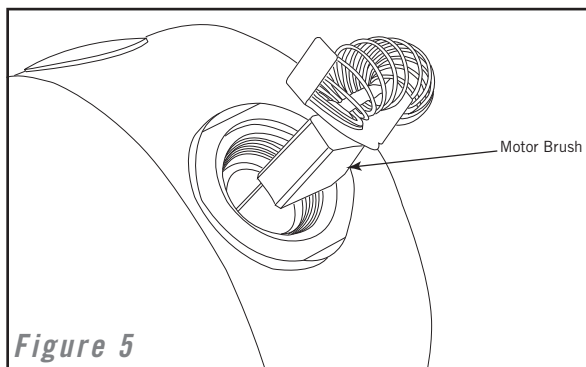

If the surface of the brush/brushes is pitted, rough, or has burn marks, replace the motor brush/brushes.

- 6) Stone the surface of the motor commutator and blow out particles away from motor with an air compressor.
- 7) Install/insert old or new motor brush/brushes, making sure that the brushes slide in and out easily.
- 8) Affix motor brush cover.
- 9) Plug-in treadmill, start it up and let it run for about 1 hour, at 5 mph, to allow the brush/brushes to be seated properly.